

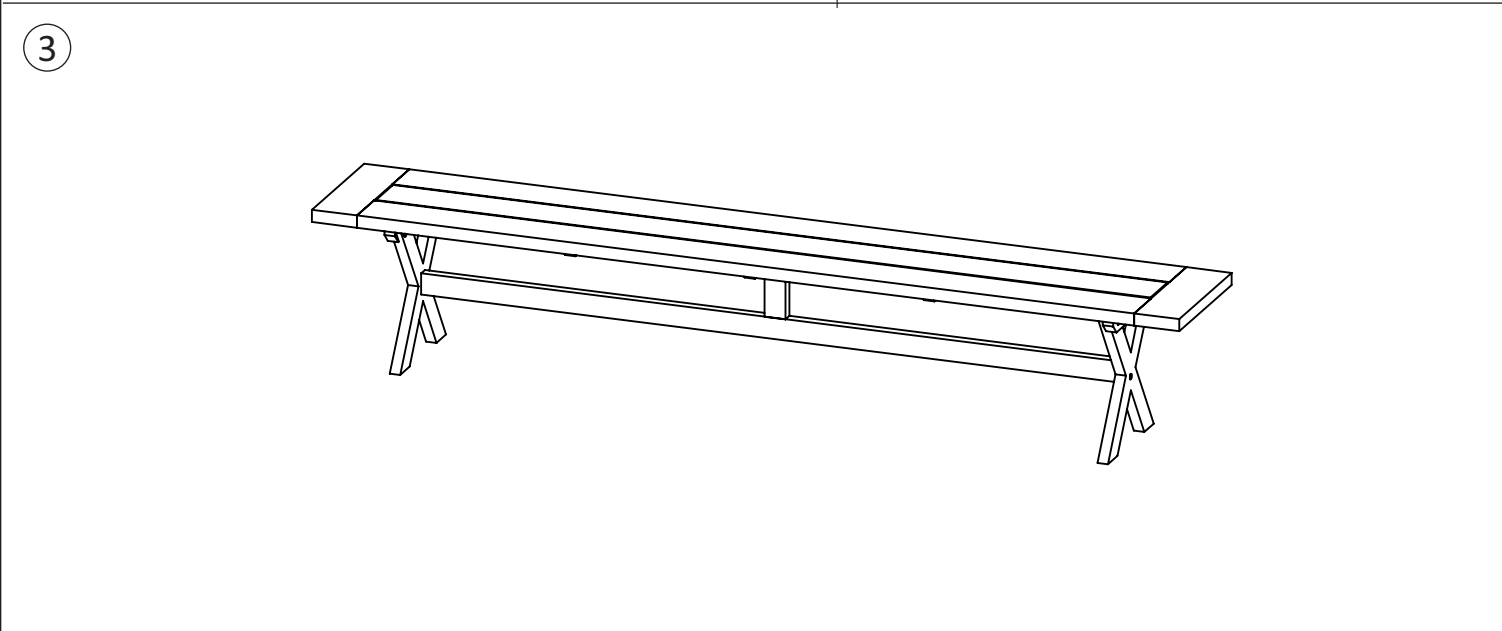

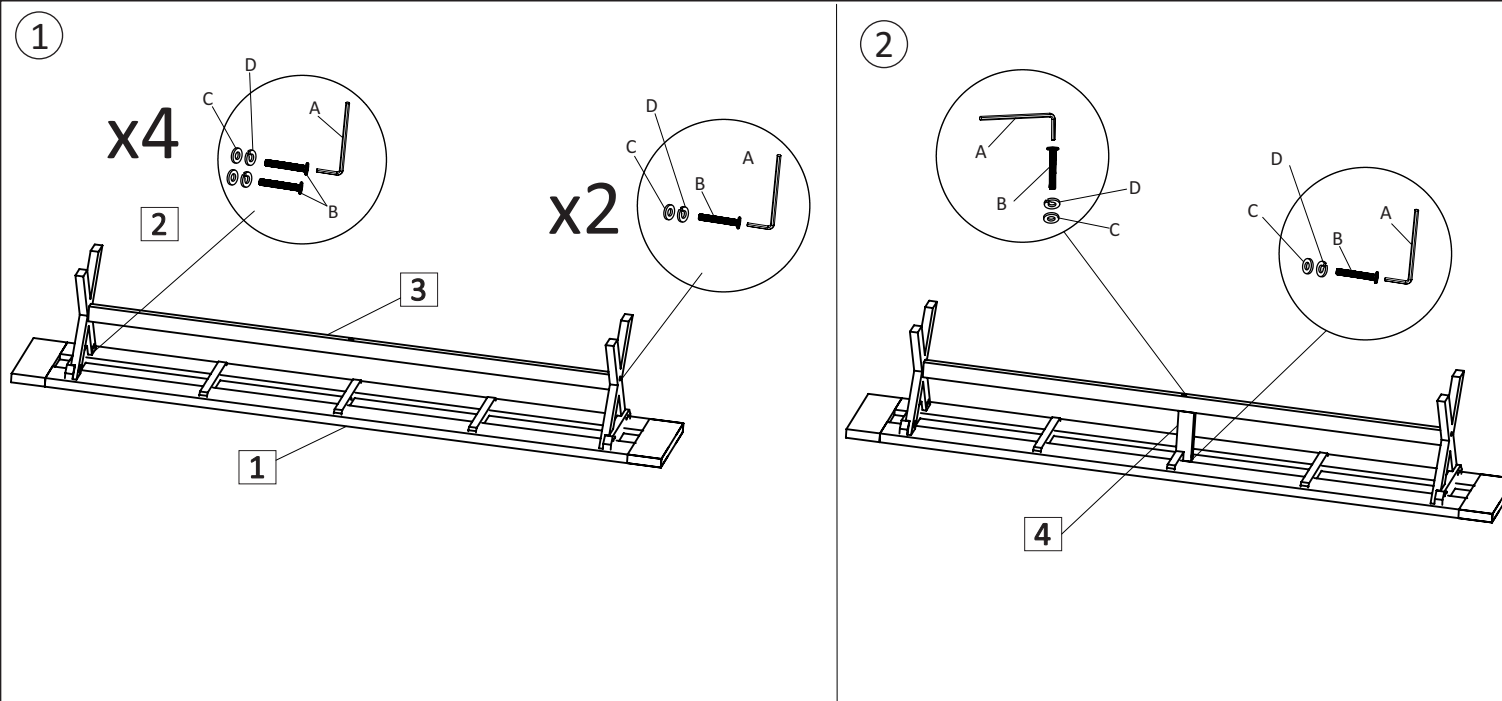





ASSEMBLY INSTRUCTION



PARTS INVENTORY		
ID	DESCRIPTION	QTY
1		1
2		2
3		1
4		
D	Warping washers 	12
C	Washer M8 	12
B	Bolt M8 x 40MM 	12
A	Allen Key 4mm 	1

ASSEMBLY INSTRUCTION



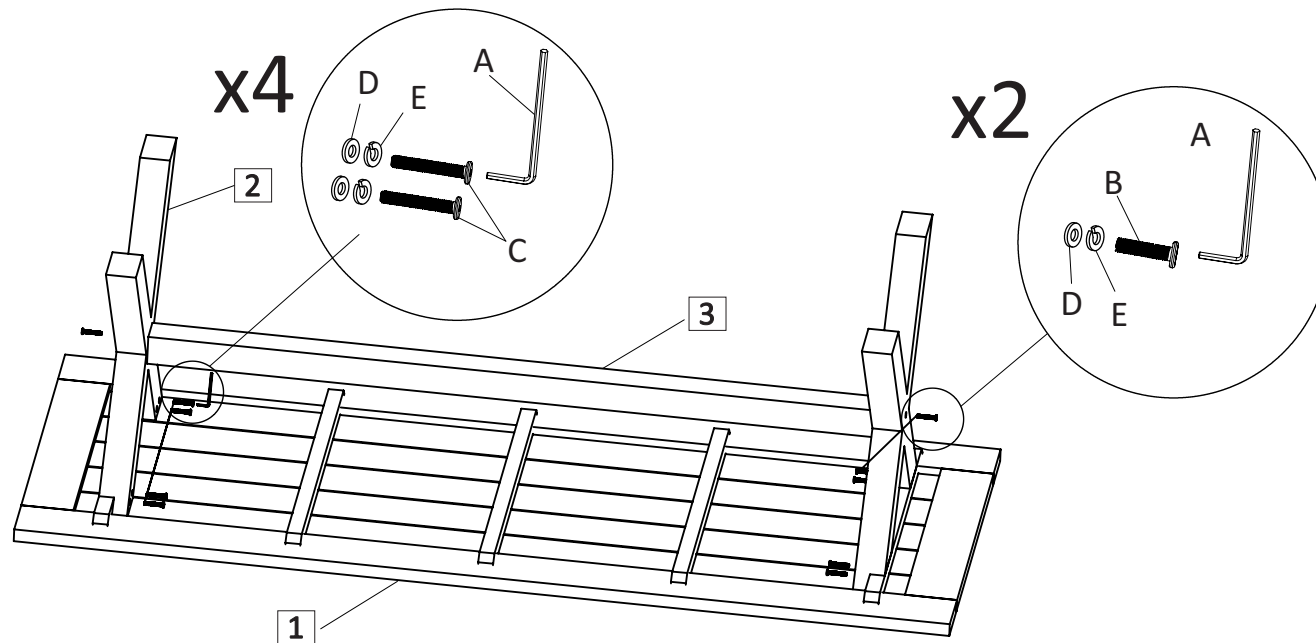



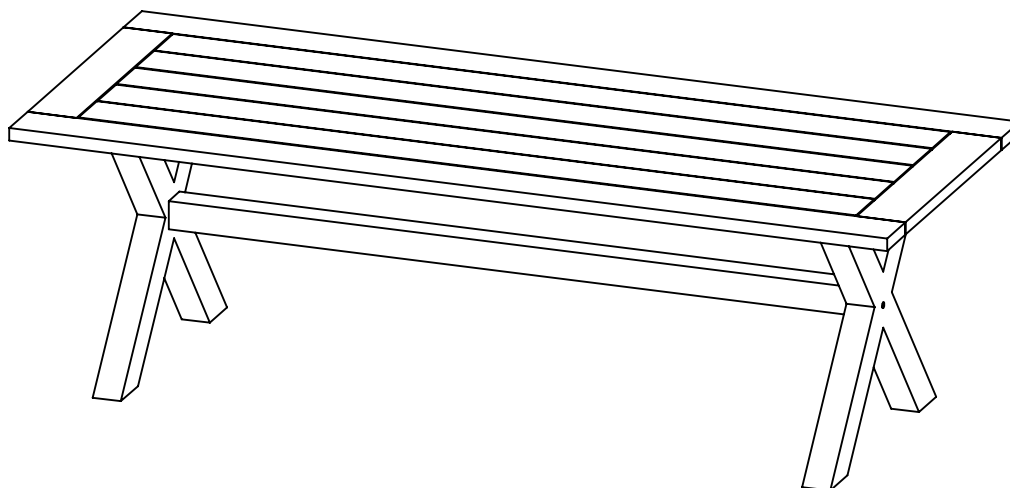

1

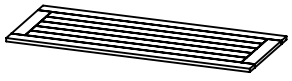

2



PARTS INVENTORY

ID	DESCRIPTION	QTY
1		1
2		2
3		1
E	Warping washers 	10
D	Washer M8 	10
C	Bolt M8 x 50MM 	8
B	Bolt M8 x 70MM 	2
A	Allen Key 4mm 	1